

Incremental encoders

Blind hollow shaft $\varnothing 6$ to $\varnothing 16$ mm
1000...10000 pulses per revolution

ITD 21 A 4 Y10



ITD 21 A 4 Y10 with coupling CPS37

Features

- Encoder with coupling max. $\varnothing 16$ mm
- Max. 10000 pulses per revolution
- Optical sensing
- Centering alignment $\varnothing 70$ mm, mounting screw hole circle $\varnothing 77$ mm
- TTL or HTL output signals
- Flange socket radial or axial

Technical data - electrical ratings

Voltage supply	5 VDC ± 5 % 8...30 VDC
Reverse polarity protection	Yes
Consumption w/o load	≤ 100 mA
Pulses per revolution	1000...10000
Reference signal	Zero pulse, width 90°
Sensing method	Optical
Output frequency	≤ 300 kHz (TTL) ≤ 160 kHz (HTL)
Output signals	A, B, N + inverted
Output stage	TTL linedriver (short-circuit proof) HTL push-pull (short-circuit proof)
Interference immunity	DIN EN 61000-6-2
Emitted interference	DIN EN 61000-6-3

Technical data - mechanical design

Size (flange)	$\varnothing 58$ mm
Shaft type	$\varnothing 6...16$ mm (blind hollow shaft)
Motor shaft tolerance	0.25 mm axial 0.5 mm radial
Protection DIN EN 60529	IP 65
Operating speed	≤ 8000 rpm
Starting torque	≤ 0.01 Nm (+20 °C)
Materials	Housing: aluminium, black, powder-coated Shaft: stainless steel
Operating temperature	-20...+70 °C -30...+70 °C
Relative humidity	90 % non-condensing
Resistance	DIN EN 60068-2-6 Vibration 10 g, 55-2000 Hz DIN EN 60068-2-27 Shock 30 g, 11 ms
Connection	Connector M23 type 2, 12-pin
Weight approx.	430 g

Incremental encoders

Blind hollow shaft $\varnothing 6$ to $\varnothing 16$ mm
1000...10000 pulses per revolution

ITD 21 A 4 Y10

Part number

ITD 21 A 4 Y10

		NI			IP65
--	--	----	--	--	------

Protection
IP65 IP 65

Blind hollow shaft

6 $\varnothing 6$ mm
10 $\varnothing 10$ mm
11 $\varnothing 11$ mm
12 $\varnothing 12$ mm
14 $\varnothing 14$ mm
15 $\varnothing 15$ mm
16 $\varnothing 16$ mm

Operating temperature

S -20...+70 °C
W -30...+70 °C

Connection

D2SR12 Flange socket type 2, pin contacts, radial, 12-pin
D2SA12 Flange socket type 2, pin contacts, axial, 12-pin

Output signals

NI A, A inv, B, B inv, 0, 0 inv

Voltage supply / signals

T 5 VDC / TTL level, linedriver
H 8...30 VDC / HTL level, push pull
R 8...30 VDC / TTL level, linedriver

Pulse number - see table

Pulse number

1000	1440	2048	4000	7200
1024	1500	2500	4096	8192
1200	1800	3000	5000	9000
1250	2000	3600	6000	10000

Accessories

Connectors and cables

11072792 Connector S2BG12, 1 m cable (ITD)

Incremental encoders

Blind hollow shaft $\varnothing 6$ to $\varnothing 16$ mm
1000...10000 pulses per revolution

ITD 21 A 4 Y10

Output signals

Clockwise rotation when looking at the mounting side.

NI-Output signals

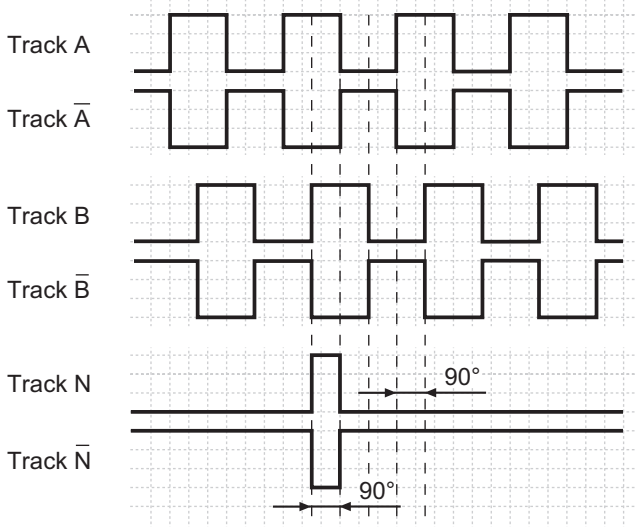

Terminal assignment

Connector	Assignment
Pin 5	Track A
Pin 6	Track A inv.
Pin 8	Track B
Pin 1	Track B inv.
Pin 3	Track N
Pin 4	Track N inv.
Pin 12	UB
Pin 10	GND
Pin 2	UB-Sense
Pin 11	GND-Sense
Pin 9	–
Pin 7	–

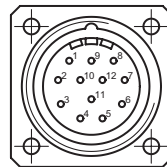

Trigger level

Outputs	Linedriver
Output level High	≥ 2.4 V
Output level Low	≤ 0.5 V
Load	≤ 70 mA

Outputs	Push-pull short-circuit proof
Output level High	$\geq UB - 3$ V
Output level Low	≤ 1.5 V
Load	≤ 70 mA

Dimensions

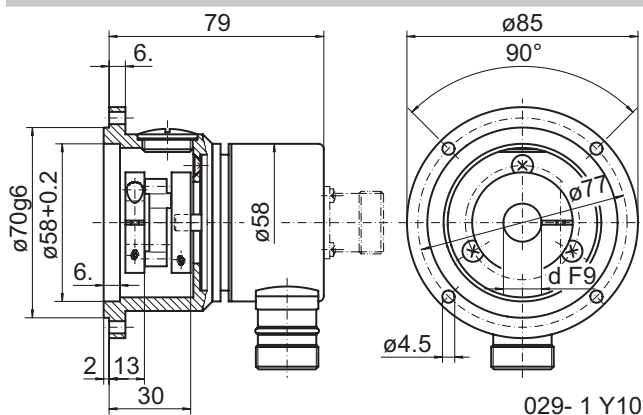

Incremental encoders
Blind hollow shaft $\varnothing 6$ to $\varnothing 16$ mm
1000...10000 pulses per revolution

ITD 21 A 4 Y10